

# TANDBERG

## TCD 440 A Cassette Deck

### Technical data and description

#### Block diagram

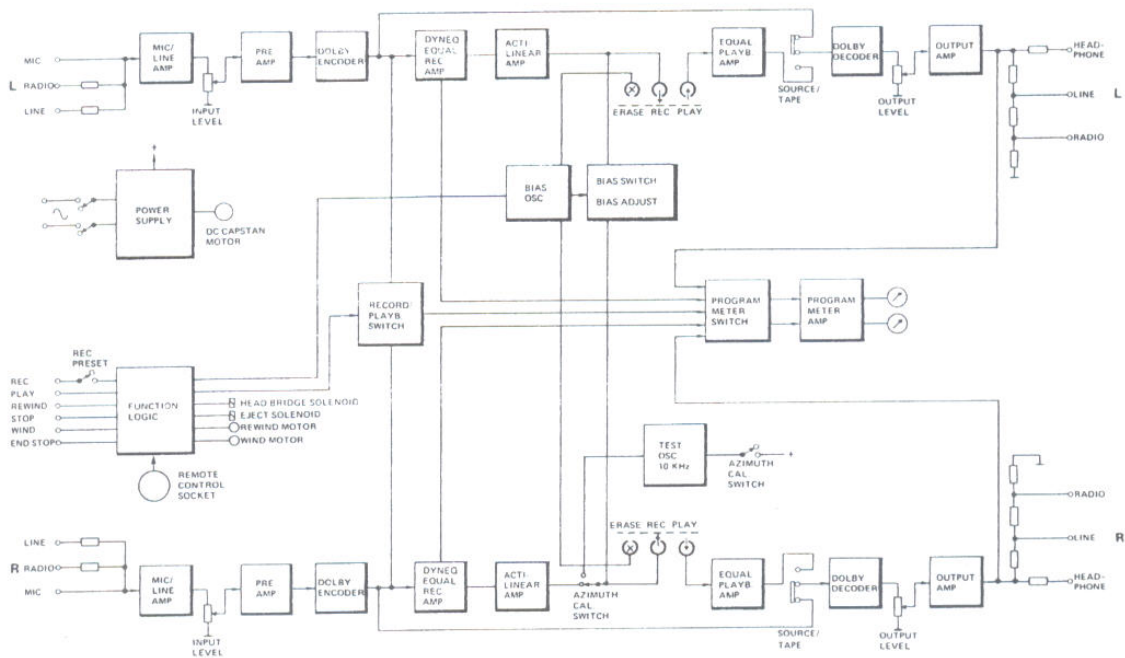

Figure 1 Block diagram, TCD 440A

#### Technical data

Supply voltage	230 V $\pm$ 10%, 50 Hz 115 V $\pm$ 10%, 60 Hz
Power consumption	40 watts
Tape speed	1 7/8" per second
Speed tolerance, maximum*	$\pm$ 0.5%
Speed variations, maximum	
IEC	0.15%
Weighted RMS record/playback	0.12%
Frequency range (Hz)	20 - 20000 Hz
$\pm$ 3 dB	
Signal/tape noise measured with Fuji Metal tape	
IEC A-curve	70 dB
IEC Linear RMS	59 dB
Channel separation (attenuation) at 1 kHz, min.	
between sides A - B	60 dB
between tracks 1 - 2	35 dB
TDH distortion from tape with 0 dB record level	
Ferric and Chrome (Type I and II)	< 1%
Metal (Type IV)	< 3%
Erasing (Metal tape)	> 76 dB

#### Inputs:

Input impedance/sensitivity/max. volts  
with 400 Hz

Mic. Left and Mic. Right

RADIO

INPUT LEFT/RIGHT

0.15 mV - 20 mV\*\*

47 k ohms/ 8 mV - 1 V

470 k ohms/80 mV - 10 V

#### Outputs:

Minimum load impedance/max. voltage  
with unloaded output

RADIO

OUTPUT LEFT/RIGHT

Headphones

5 k ohms/775 mV

100 ohms/ 1.5 V

8 ohms/ 1.5 V

#### Dimensions:

Width 18 5/16" (46.5 cm)

Height 4" (10 cm)

Depth 8 7/8" (22.5 cm)

Weight 14.5 lbs (6.7 kg)

\* With nominal mains voltage/frequency and normal operating temperature.

\*\* The microphone inputs are matched to dynamic microphone and the sensitivity matches itself automatically to the impedance of the microphone.

**DYNEO — the unique dynamic equalization system**

Conventional recording amplifiers have a steadily rising gain at high frequencies in order to obtain a flat frequency response over the entire audio frequency range. This rising gain (equalization) has a bad effect on high recording levels (loud passages) where a distortion-free performance is more important than a linear frequency response.

Tandberg engineers have recently developed a unique dynamic equalization amplifier — DYNEQ — which overcomes this problem. The DYNEQ system is a self-regulating circuit where the signal level at the input determines the gain at the high frequencies. The result is optimum recordings for almost all types of music.

The user will obtain top quality recordings even if the programme contains loud, complex, high frequency passages.

Figure 2 shows the DYNEQ effect on OUTPUT LEVEL and IM DISTORTION at constant input level. Curves are drawn for a conventional recording amplifier and for a DYNEQ system (TCD 440A).

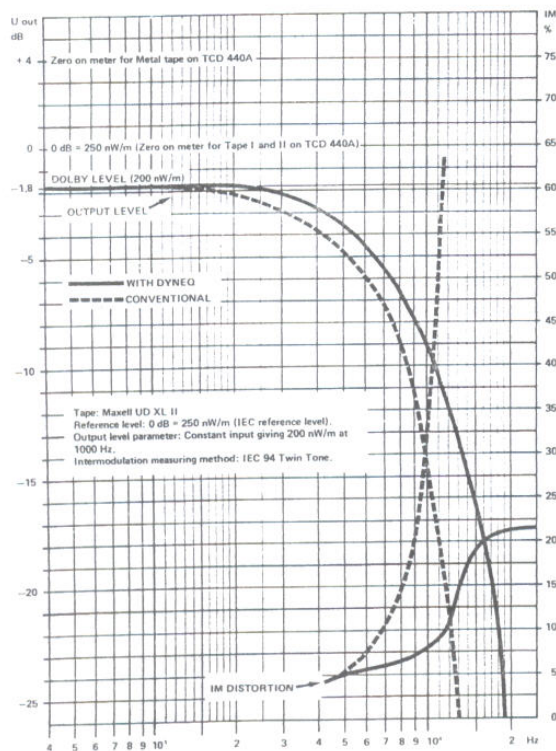

Figure 2 The DYNEQ effect on OUTPUT LEVEL and IM DISTORTION at constant input level

Most of the recordings made in daily life contains programs with an energy distribution over a wide range of high frequencies, but some of them may have rather large contributions in the high frequency area which may cause overloading of the tape in conventional recorders.

Any tape recorder system, and especially the low speed cassette format suffers from reduced signal capacity in the high frequency area and represents a weakness in the system which may cause a considerable increase in IM distortion for programs with large high frequency contents. The input signal capacity has been measured for a conventional tape recorder and is given by the dotted curve in figure 3.

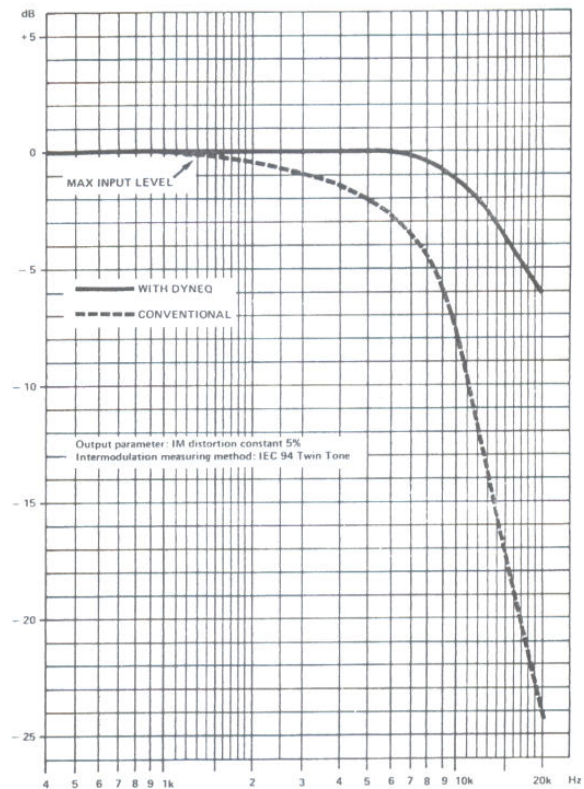

Figure 3 The DYNEQ effect on MAXIMUM INPUT LEVEL at constant IM distortion

The invention of the DYNEQ system improves the input signal capacity as given by the solid line in the same figure. The advantage for a user is an increased ability to make recordings with maximum signal to noise ratio at low and medium frequencies without creation of high frequency distortion due to tape saturation.

### How the DYNEQ circuit operates

The frequency response is determined by the feedback network consisting of all the components in the feedback path.

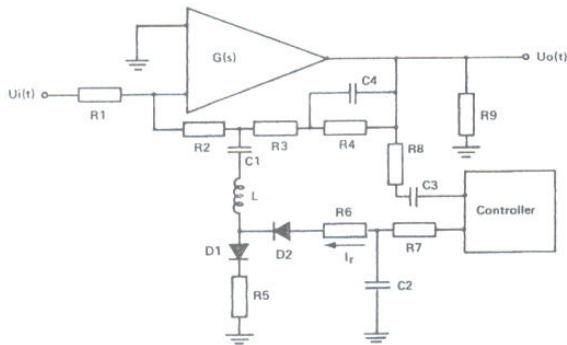

Figure 4 The DYNEQ circuit

The resonant LC circuit gives peaking in the frequency response at 20 kHz and the degree of peaking is determined by the effective resistance in series with the inductor. This resistance is determined by the two diodes and R5, R6. The diode resistance is a function of the current through the diodes and thus the degree of peaking can be controlled by the current  $I_r$ . The controller circuit detects the signal amplitude and changes the current  $I_r$ , according to the level of the high frequency signals in the programme.

At low levels the current  $I_r$  remains constant equal to 2 mA which results in a low diode resistance and thus a peaking at high frequencies mainly determined by R5 and R6 in parallel.

As the signal amplitude increases beyond a fixed level, the controller operates and reduces the current  $I_r$ , and the diode resistance is increased and consequently the pre-emphasis is reduced. At extremely high levels the control current  $I_r$  equals zero, then the LC circuit has no influence at all and the equalization curve becomes flat.

### The Actilinear Recording system

A correct interaction between the tapes physical properties and the recorder is an absolute requirement for a successful recording. The Tandberg Actilinear Recording system presents to the Hi-Fi enthusiast an innovation which offer greater possibilities to achieve high quality recordings, as it is designed to take advantage of the new generation of tapes.

The considerable advantage of the compact cassette system is its small size and mechanical size which entails compatibility with all recordings all over the world. The ease of use helps to enlarge the area of applications which in turn forces new requirements for an improved quality. The improvements are carried on in two different environments. The hardware manufacturers are developing new designs like the Actilinear Recording system from Tandberg and the tape manufacturers are developing tapes with better magnetic and mechanical properties. A close relation between the two development areas ensures the best possible offer to the user.

Two of the most important properties of a tape are the maximum magnetic flux density and the coercivity. A high flux density increases the undistorted signal and gives a higher signal to noise ratio at low and medium frequencies. An increased coercivity improves the high frequency response, especially at low tape speeds, and this explains the reason for the invention of high coercivity metal tape in the low speed cassette format.

This new generation of high coercivity metal tapes has increased the demands on other parts of the recording chain. The Actilinear Recording system from Tandberg offers a number of advantages compared to conventional designs. The results is less intermodulation and less interference between recording signal and oscillator. The actilinear recording amplifier has 15 dB overload margin which means that it can be used for recording on every new high coercivity tape, any metal tape included. By means of the active semiconductor circuits we have succeeded in designing a recording amplifier system which is more linear, especially at high frequencies, and hence the name *Actilinear*.

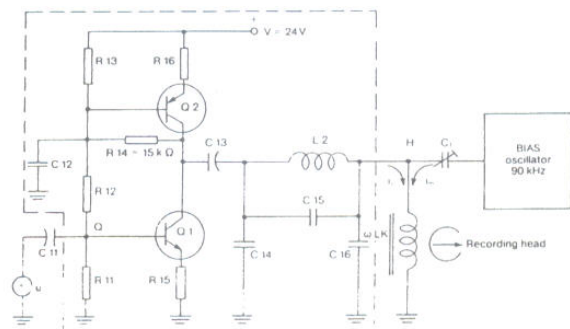

Figure 5 The Actilinear circuit

---

### Metal tape — the ultimate recording medium

---

A correctly designed tape recorder is always constructed so that the total quality of the recording is limited only by the electro-acoustical properties of the tape, and not by the tape recorder's electronic circuits or mechanical properties.

The most serious limitations in sound quality have always been distortion at high signal levels and noise at low signal levels. These limitations are directly determined by the properties of the magnetic particles used on the tape surface. Continuous research and development has therefore been carried out to create tapes with improved properties. The latest research work has led to a real break-through in tape technology — the pure metal particle tape.

The improvements result in considerable lower distortion at high signal levels. The high frequencies in particular will sound cleaner because the tape is capable of storing these signals without introducing distortion.

Metal tapes require a far higher recording-, bias-, and erasure field strength than all other tapes. Therefore the tape recorder must be specially designed to have the full capacity to handle metal tapes. The TCD 440A is designed to take full advantage of metal tapes.

---

### Summary

---

Tandberg TCD 440A is our answer to the latest development in tape research, the metal tapes. The introduction of the *DYNEQ Equalization circuit* and the *Actilinear Recording* (both patented in several countries) makes TCD 440A face today's demand for quality, as it fully takes advantage of the properties offered by the metal tapes and other modern tapes.

Measurements and listening tests carried out in our laboratories have shown that the new systems give better results than any other system we have tested up to now.

*A break-through in cassette technology.*

TANDBERG A/S  
ELECTRONIC DIVISION  
P.O. Box 55, Bogerud  
N — OSLO 6 — Norway