

# PARTS LIST

## **BX-1**

MONAURAL POWER AMPLIFIER

### ■ CONTENTS

EXPLODED VIEW (BOTTOM VIEW) .....	1
PARTS LIST .....	2
EXPLODED VIEW (TOP VIEW) .....	3
PARTS LIST .....	4/5
PARTS LIST (ELECTRICAL) .....	6 ~ 16

U : U.S.A. model

E : European model

SINCE 1887



**YAMAHA**

NIPPON GAKKI CO., LTD. HAMAMATSU, JAPAN

004457

# EXPLODED VIEW (BOTTOM VIEW)

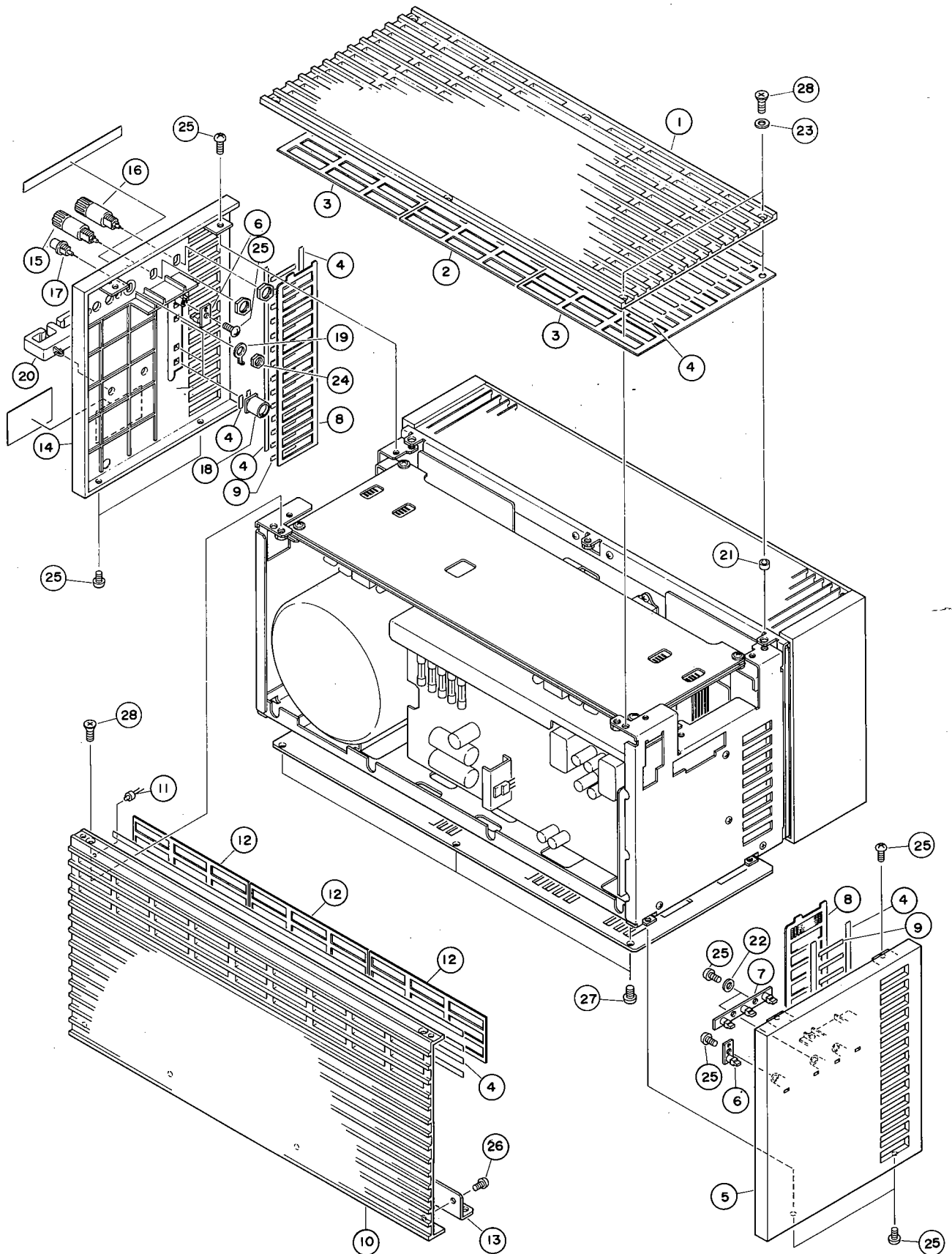

■ PARTS LIST

Ref. No.	Part No.	Description	部 品 名	Remarks	Common Model	Markets		
※ 1	BA 07:88:40	Top Panel	ト ッ プ パ ネ ル					
※ 2	AA 60:24:40	Center Grille (A)	セ ン タ ー グ リ ル (A)					
※ 3	AA 60:24:50	Grille (B)	グ リ ル (B)					
4	CB 07:41:90	Tape	ダ ブ ル タ ッ ク テ ー プ					
※ 5	CB 09:68:00	Front Panel	フ ロ ン ト パ ネ ル					
※ 6	NA 07:43:50	L.E.D. (Single) Circuit Board	L E D シ ン グ ル シ ー ト					
※ 7	NA 07:43:40	L.E.D. (Triple) Circuit Board	L E D ト リ プ ル シ ー ト					
※ 8	AA 60:24:60	Grille (C)	グ リ ル (C)					
9	CB 09:86:80	Tape	補 強 テ ー プ					
※ 10	BA 07:88:30	Side Panel	サ イ ド パ ネ ル					
※ 11	iF 00:20:00	L.E.D.	SLC22UR L E D					
※ 12	AA 60:24:70	Grille (D)	グ リ ル (D)					
※ 13	BA 07:88:80	Angle	ア ン グ ル					
※ 14	CB 09:68:10	Rear Panel	リ ア パ ネ ル					
※ 15	LA 00:41:50	Speaker Terminal (Gray)	ス ピ ー カ ー 端 子 (灰)					
※ 16	LA 00:41:60	Speaker Terminal (Cream)	ス ピ ー カ ー 端 子 (ク リ ー ム)					
17	NB 08:26:40	Ground Terminal Ass'y	ア ー ス 端 子 Ass'y		C-2			
18	NB 08:46:50	Push Button Ass'y (F)	プ ッ シ ュ ボ タ ン Ass'y (F)					
19	LA 00:17:70	Ground Lug	φ8.2 ア ー ス ラ グ					
※ 20	CB 09:78:90	Cord Cramper	コ ー ド ク ラ ン パ ー					
※ 21	EV 99:00:30	Spacer	φ4 x 5 ZMC2-Y ス ペ ー サ ー					
※ 22	EV 99:00:10	Plastic Washer	φ3, t = 5 プ ラ ス チ ッ ク ワ ッ シ ャ ー					
23	EV 90:00:70	Washer	4 x 6 x 0.25 ポ リ ス ラ イ ダ ー ワ ッ シ ャ ー					
24	LA 00:16:80	Hexagonal Nut	六 角 ナ ッ ト					
25	EN 33:00:10	Bind Head Tapping Screw	3 x 8 ZMC2-B&#226 バ イ ン ド タ ッ ピ ン グ ネ ジ					
26	EN 33:00:20	"	3 x 6 " "					
※ 27	EN 33:00:40	"	4 x 10 " "					
28	EB 34:01:20	Flat Head Screw	M4x12 FCM3-B&#226 サ ラ 小 ネ ジ					

※ New Parts (新規部品)

# EXPLODED VIEW (TOP VIEW)

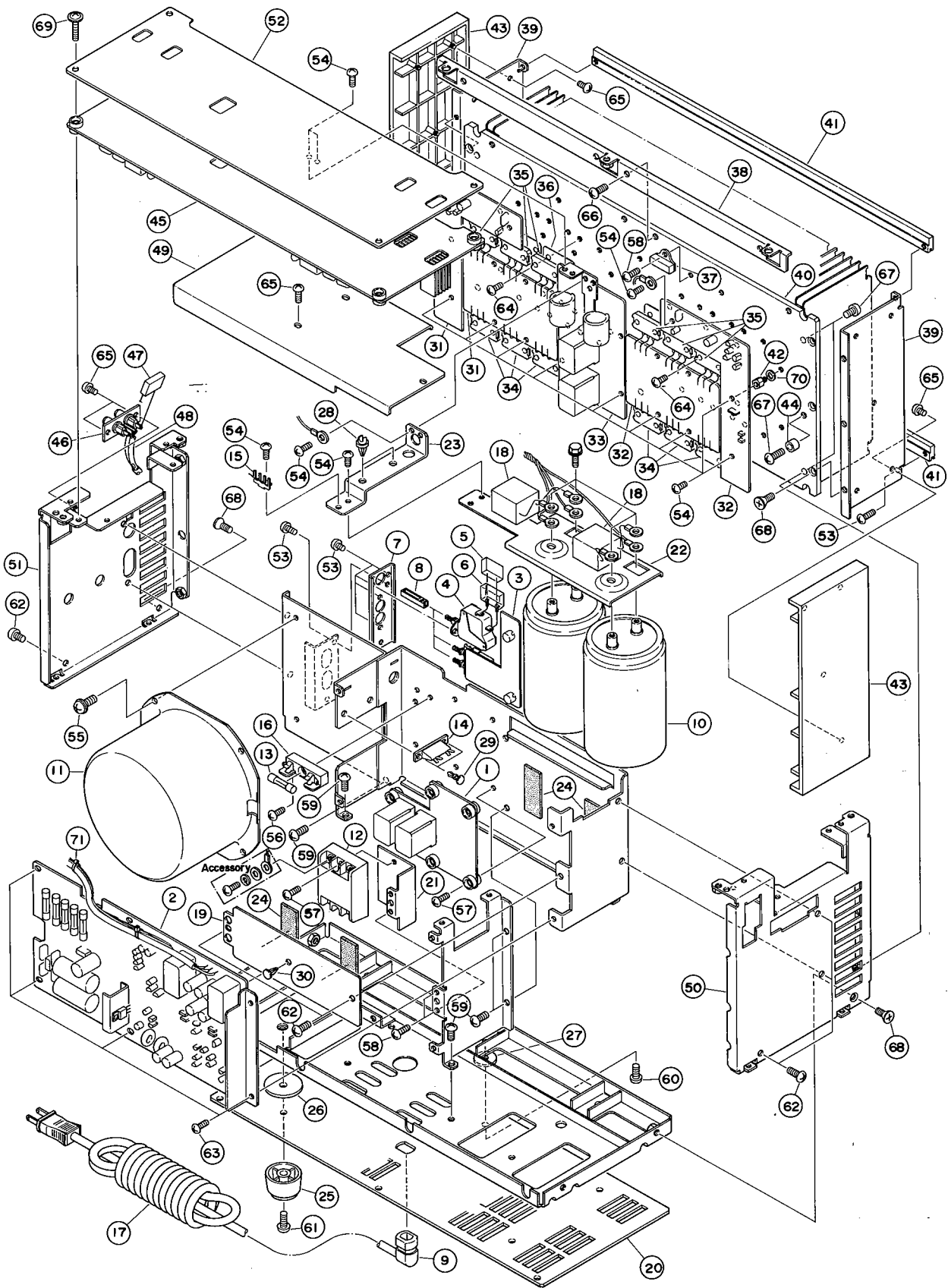

**PARTS LIST**

Ref. No.	Part No.	Description	Remarks	Common Model	Markets
1	NA:07:43:10	Relay Circuit Board	リレーシート		
2	NA:07:43:20	Muting Circuit Board	ミュートシート		
3	NA:07:43:30	Push Switch Circuit Board	プッシュスイッチシート		
4	KA:80:25:50	Power Switch	パワースイッチ		U
5	KA:80:21:70	"	"		E
6	FR:34:41:00	Ceramic Capacitor	セラミックコン		U
7	FR:16:41:00	Metalized Paper Capacitor	M P コン		E
8	CB:07:21:90	Cover for Capacitor	コンデンサカバー		E
9	CB:09:52:60	"	"		U
10	AA:60:24:80	Switch Holder	スイッチホルダー		
11	CB:08:48:30	Push Rod	プッシュロッド	T-2	E
12	CB:09:69:80	Cord Stopper	コードストッパー		U
13	CB:61:24:40	"	"		U
14	FZ:00:23:00	Electrolytic Capacitor	ケミコンネジ式		U
15	GA:65:65:00	Power Transformer	電源トランス		U
16	GA:65:66:00	"	"		E
17	IH:00:08:30	Diode Bridge	ダイオードブリッジ		U
18	KB:00:15:40	Fuse	ヒューズ		U
19	KB:00:17:60	"	"		E
20	LA:00:29:50	Connect Terminal	2 P 中継端子台		U
21	LA:00:32:10	Ground Terminal	4 P 一端子 III 型		U
22	LB:20:13:40	Fuse Holder	ヒューズホルダー		E
23	LB:20:14:70	"	"		U
24	MG:00:07:10	Power Cord	電源コード		E
25	MG:00:09:10	"	"		U
26	MZ:07:85:80	Mylar Capacitor Ass'y	マイラーコン Ass'y		E
27	AA:60:24:30	Pressure Plate	プレッシャープレート		
28	BA:07:88:70	Bottom Cover	ボトムカバー		
29	BA:07:89:00	Plate (Diode Bridge)	ダイオードプレート		
30	BB:06:88:60	Booth-Bar (A)	ブースバー (A)		
31	BB:06:88:70	Booth-Bar (B)	ブースバー (B)		
32	CB:08:51:40	Anti Vibration Tape	防振テープ		
33	CB:08:77:40	Leg	脚		
34	CB:09:77:60	Leg Spacer (A)	レッグスパー(A)		
35	CB:09:77:80	Leg Spacer (B)	レッグスパー(B)		
36	CB:09:79:20	Rod Holder	ロッドホルダー		
37	CB:06:88:80	Plastic Rivet	プラスチックリベット		
38	CB:08:17:00	Clip	クリップ		
39	NA:07:42:80	Bias Power (+) Circuit Board	バイアスパワ(+)-シート		
40	NA:07:42:90	Bias Power (-) Circuit Board	バイアスパワ(-)-シート		
41	NA:07:43:00	Output Circuit Board	出力シート		
42	IA:10:35:10	Transistor	トランジスタ	TR602,604,606 TR652,654,656 TR651,653,655	
43	IC:25:65:10	"	"		
44	IL:00:05:00	Mica Base	マイカベース		
45	KA:00:00:60	Thermal Guard	サーマルガード		
46	AA:60:24:10	Top Stay	トップステー		
47	AA:60:24:20	Plate (Protector)	プロテクター金具		
48	BA:07:88:10	Heat Sink	放熱板		
49	BA:07:89:10	Fin Guard	フィンガード		
50	BB:06:89:10	Boss	ボス		
51	CB:09:68:20	Protector	プロテクター		
52	AA:60:26:40	Collar	カラー		
53	NA:07:42:70	Pre Drive Circuit Board	プリドライブシート		

\* New Parts (新規部品)

Ref. No.	Part No.	Description	Remarks	Common Model	Markets
46	LB:20:16:20	2P Pin Jack	2 P ピンジャック		
47	FC:10:61:00	Metalized Mylar Capacitor	M M コン		
48	CB:09:45:50	Shield Tube	シールドチューブ		
49	AA:60:24:00	Shield Plate	シールド板		
50	BA:07:88:50	Front Frame	フロントフレーム		
51	BA:07:88:60	Rear Frame	リアフレーム		
52	CB:09:83:60	Blind	ブラインド		
53	ED:93:00:60	Bind Head Screw	M3x6 ZMC2-BR		
54	ED:83:00:60	"	M3x6 Copper		
55	EH:95:01:20	Pan Head Screw	M5x12 ZMC2-BR		
56	EK:97:00:10	Pan Head Tap-Tyte Screw	3x8		
57	EK:95:00:40	Bind Head Tap-Tyte Screw	3x16		
58	EK:95:00:20	"	3x6		
59	EK:95:00:50	"	4x6		
60	EK:95:00:10	"	4x10		
61	EK:95:00:80	"	4x25		
62	EK:95:00:60	"	4x8		
63	EK:93:00:10	B.W. Head Tapping Screw	3x8 ZMC2-BK(Typell) BWヘッドタッピングネジ		
64	ED:83:00:80	Bind Head Screw	M3x8 ZMC2-BR		
65	EK:39:50:40	Bind Head Tap-Tyte Screw	3x8		
66	ED:94:00:60	Bind Head Screw	M4x6		
67	ED:94:01:20	"	M4x12		
68	EB:94:01:20	Flat Head Screw	M4x12		
69	EK:93:50:10	B.W. Head Tapping Screw	3x20		
70	EV:41:00:40	Toothed Lock Washer	4S ZMC2-Y		
71	CB:06:92:50	Binding Tie	インシュロックタイ		
		Accessory Ass'y	付属品 Ass'y		
	MI:06:98:90	Cord	ケーブル		

\* New Parts (新規部品)

PARTS LIST (ELECTRICAL)

Ref. No.	Part No.	Description	部 品 名	Remarks	Common Model	Markets
	NA:0742:70	Pre-Drive Circuit Board	プリドライブ基板			
C101	FU 35 23:90	Mica Cap.	マイカコン			
C106	FT 15 51:00	Polypropylene Film Cap.	ポリプロピレンフィルムコン			
C107	FT 15 41:00	"	"			
C108	FT 15 51:00	"	"			
C109	FT 16 33:90	"	"			
C111	FU 35 16:80	Mica Cap.	マイカコン			
C112	FC 10 81:00	Metalized Mylar Cap.	マイカコン			
C114	FU 35 12:70	Mica Cap.	マイカコン			
C115	FT 15 51:00	Polypropylene Film Cap.	ポリプロピレンフィルムコン			
C121	FV 24 74:70	Electrolytic Cap.	アルミ電解コン			
C123	FU 35 25:80	Mica Cap.	マイカコン			
C125	FU 35 21:00	"	"			
C127	FT 15 41:00	Polypropylene Film Cap.	ポリプロピレンフィルムコン			
C128	FT 15 41:50	"	"			
C130	FT 15 41:00	"	"			
C131	FT 35 07:00	Mica Cap.	マイカコン			
C132	FU 35 03:00	"	"			
C133	FU 35 05:00	"	"			
C134	FU 35 24:70	"	"			
C135	FU 24 81:00	Electrolytic Cap.	アルミ電解コン			
C136	FT 15 44:70	Polypropylene Film Cap.	ポリプロピレンフィルムコン			
C138	FV 24 81:00	Electrolytic Cap.	アルミ電解コン			
C139	FU 35 22:20	Mica Cap.	マイカコン			
C141	FU 35 22:20	"	"			
C142	FT 15 51:00	Polypropylene Film Cap.	ポリプロピレンフィルムコン			
C144	FU 35 12:20	Mica Cap.	マイカコン			
C145	FU 35 22:20	"	"			
C151	FT 15 51:00	Polypropylene Film Cap.	ポリプロピレンフィルムコン			
C155	FT 15 51:00	"	"			
C159	FU 35 11:20	Mica Cap.	マイカコン			
C161	FU 35 21:00	"	"			
C163	FC 10 81:00	Metalized Mylar Cap.	マイカコン			
C165	FU 35 11:00	Mica Cap.	マイカコン			
C167	FU 35 24:70	"	"			
C169	FC 10 81:00	Metalized Mylar Cap.	マイカコン			
C171	FT 15 44:70	Polypropylene Film Cap.	ポリプロピレンフィルムコン			
C175	FT 15 51:00	"	"			
C179	FA 11 41:00	Mylar Cap.	マイカコン			
C181	FT 15 31:80	Polypropylene Film Cap.	ポリプロピレンフィルムコン			
C185	FT 15 31:50	"	"			
C189	FC 10 61:00	Metalized Mylar Cap.	マイカコン			
C193	FT 15 41:00	Polypropylene Film Cap.	ポリプロピレンフィルムコン			
C197	FT 16 32:70	"	"			
C201	FZ 00 22:40	Film Cap.	フィルムコン			
C203	FU 35 11:20	Mica Cap.	マイカコン			
R101	HU 27 52:20	Metal Film Resistor	金属薄膜抵抗			
R102	HU 75 72:70	"	"			
R103	HU 75 71:80	"	"			
R104	HU 75 55:60	"	"			
R105	HU 75 62:20	"	"			
R106	HU 75 63:30	"	"			

\* New Parts (新規部品)

Ref. No.	Part No.	Description	部 品 名	Remarks	Common Model	Markets
R107	HU 75 71:20	Metal Film Resistor	金属薄膜抵抗			
R108	HU 75 54:70	"	"			
R111	HU 75 58:20	"	"			
R115	HU 75 62:70	"	"			
R116	HU 35 61:20	Carbon Resistor	カーボン抵抗			
R117	HU 75 55:60	Metal Film Resistor	金属薄膜抵抗			
R118	HU 75 54:70	"	"			
R120	HU 75 52:20	"	"			
R124	HU 75 72:20	"	"			
R122	HU 75 52:20	"	"			
R130	HU 75 71:50	"	"			
R133	HU 75 52:20	"	"			
R137	HU 75 54:70	"	"			
R138	HU 27 52:20	"	"			
R140	HU 75 73:30	"	"			
R141	HU 75 71:80	"	"			
R143	HU 75 63:00	"	"			
R144	HU 75 64:70	"	"			
R146	HU 75 63:00	"	"			
R147	HU 75 51:00	"	"			
R153	HU 75 51:00	"	"			
R155	HU 75 51:80	"	"			
R156	HU 75 51:00	"	"			
R157	HU 75 73:90	"	"			
R159	HU 75 62:20	"	"			
R160	HU 75 61:50	"	"			
R163	HU 75 61:50	"	"			
R164	HU 75 62:20	"	"			
R165	HU 27 61:10	"	"			
R166	HU 75 62:20	"	"			
R167	HU 75 64:70	"	"			
R168	HU 75 54:70	"	"			
R170	HU 75 51:00	"	"			
R173	HU 75 62:70	"	"			
R174	HU 75 52:20	"	"			
R176	HU 75 52:20	"	"			
R177	HU 75 71:50	"	"			
R179	HU 75 52:20	"	"			
R181	HU 75 51:00	"	"			
R183	HU 75 62:70	"	"			
R186	HU 27 58:00	"	"			
R187	HU 27 52:00	"	"			
R188	HU 75 54:70	"	"			
R189	HU 75 71:80	"	"			
R191	HU 75 71:50	"	"			
R193	HU 75 55:60	"	"			
R195	HU 75 72:20	"	"			
R197	HU 75 64:70	"	"			
R199	HU 75 58:20	"	"			
R201	HU 75 64:70	"	"			
R217	HU 75 61:00	"	"			
R221	HU 75 58:20	"	"			
R223	HU 75 55:60	"	"			

\* New Parts (新規部品)

Ref. No.	Part No.	Description	部 品 名	Remarks	Common Model	Markets		
* R225,226	HU 75:72:20	Metal Film Resistor	22kΩ	金 属 被 膜 抵 抗				
* R227,228	HU 75:64:70	"	4.7kΩ	"				
* R229,230	HU 27:51:10	"	110Ω	"				
* R231,232	HU 27:61:20	"	1.2kΩ	"				
* R233,234	HU 75:58:20	"	820Ω	"				
* R235,236	HU 27:51:00	"	100Ω	"				
* R237,238	HU 75:64:70	"	4.7kΩ	"				
* R239~244	HU 75:71:50	"	15kΩ	"				
* R255~260	HU 75:52:20	"	220Ω	"				
* R261~264	HU 75:62:70	"	2.7kΩ	"				
* R265~268	HU 75:71:50	"	15kΩ	"				
* R269~272	HU 75:71:00	"	10kΩ	"				
* R277~280	HU 75:62:20	"	2.2kΩ	"				
* R281~284	HU 75:68:20	"	8.2kΩ	"				
R285~288	HV 35:34:70	Flame Proof Resistor	4.7Ω RDF25	不 燃 化 カ ー ボ ン 抵 抗				
* R289~292	HU 75:62:20	Metal Film Resistor	2.2kΩ	金 属 被 膜 抵 抗				
* R297,298	HU 75:58:20	"	820Ω	"				
* R299,300	HU 75:54:70	"	470Ω	"				
* R305~308	HU 75:61:00	"	1kΩ	"				
* R309~312	HU 75:71:80	"	18kΩ	"				
R313~316	HV 35:34:70	Flame Proof Resistor	4.7Ω	不 燃 化 カ ー ボ ン 抵 抗				
* R321,322	HU 75:71:00	Metal Film Resistor	10kΩ	金 属 被 膜 抵 抗				
* R323~326	HU 47:61:80	"	1.8kΩ	"				
FR101~ FR104	HW 89:53:90	Fuse Resistor	390Ω 25mA	ヒ ュ ー ズ 抵 抗				
FR105 FR106	HW 89:56:80	"	680Ω 19mA	"				
TR101 TR102	iA 09:70:00	Transistor	2SA770(GR,BL)	ト ラ ン ジ ス タ				
TR103 TR104	iC 18:85:10	"	2SC1885(Q,R)	"				
TR105	iE 10:22:00	Dual FET	2SK146(BL,V)	デュアル F E T				
TR106	iC 19:53:30	Transistor	2SC1953(R,S)	ト ラ ン ジ ス タ				
TR107	iC 22:40:00	"	2SC2240(GR,BL)	"				
TR108 TR109	iA 10:15:70	"	2SA1015	"				
TR110 TR111	iA 09:14:30	"	2SA914(R,S)	"				
TR112 TR113	iC 22:40:00	"	2SC2240(GR,BL)	"				
TR114	iC 19:53:30	"	2SC1953(R,S)	"				
* TR115	iC 26:33:00	"	2SC2633(R,S)	"				
TR116	iC 22:40:00	"	2SC2240(GR,BL)	"				
* TR117	iA 07:33:40	"	2SA733A(Q,P)	"				
* TR118	iA 11:25:00	"	2SA1125(R,S)	"				
TR119	iC 22:40:00	"	2SC2240(GR,BL)	"				
TR120	iA 09:70:00	"	2SA970(GR,BL)	"				
TR121	iC 22:91:00	"	2SC2291(F,G)	"				
* TR122	iZ 00:01:20	Dual Transistor	μPA74V	デュアルトランジスタ				
* TR123	iZ 00:01:30	"	μPA75V	"				
TR124	iA 09:95:00	"	2SA995(F,G,H)	"				
TR125	iC 22:40:00	Transistor	2SC2240(GR,BL)	ト ラ ン ジ ス タ				
TR126	iA 09:70:00	"	2SA970(GR,BL)	"				
TR127	iC 22:40:00	"	2SC2240(GR,BL)	"				
TR128	iC 14:00:20	"	2SC1400(E)	"				
* TR129	iC 26:33:00	"	2SC2633(R,S)	"				
TR130	iA 09:70:00	"	2SA970(GR,BL)	"				
* TR131	iA 11:25:00	"	2SA1125(R,S)	"				

\* New Parts (新規部品)

Ref. No.	Part No.	Description	部 品 名	Remarks	Common Model	Markets
TR132	iA 07:50:20	Transistor	2SA750 (E)	ト ラ ン ジ ス タ		
TR133	iA 11:25:00	"	2SA1125(R,S)	"		
* TR134	iC 26:33:00	"	2SC2633(R,S)	"		
TR135~ TR138	iA 09:70:00	"	2SA970(GR,BL)	"		
TR139 TR140	iC 22:91:00	"	2SC2291(F,G)	"		
TR141~ TR144	iC 18:85:10	"	2SC1885(Q,R)	"		
* TR145 TR146	iZ 00:01:20	Dual Transistor	μPA74V	デュアルトランジスタ		
* TR147 TR150	iZ 00:01:30	"	μPA75V	"		
TR151~ TR154	iA 09:95:00	"	2SA995	"		
TR155~ TR158	iA 09:70:00	Transistor	2SA970(GR,BL)	ト ラ ン ジ ス タ		
TR159~ TR162	iA 10:15:70	"	2SA1015	"		
* TR163 TR164	iA 11:25:00	"	2SA1125(R,S)	"		
* TR165~ TR168	iC 26:33:00	"	2SC2633(R,S)	"		
TR169~ TR172	iC 04:58:30	"	2SC458C	"		
TR173~ TR176	iA 10:15:70	"	2SA1015	"		
TR177 TR178	iC 15:09:30	"	2SC1509(Q,R)	"		
TR179 TR180	iC 12:13:10	"	2SC1213A(C,D)	"		
TR181 TR182	iC 16:36:00	"	2SC1636 (1,2)	"		
TR183 TR184	iA 07:77:30	"	2SA777A(Q,R)	"		
TR185~ TR188	iC 18:85:10	"	2SC1885(Q,R)	"		
TR189~ TR192	iA 09:12:10	"	2SA912(Q,R)	"		
TR193~ TR196	iC 22:38:00	"	2SC2238(O,Y)	"		
TR197~ TR202	iA 09:68:00	"	2SA968(O,Y)	"		
TR203 TR204	iC 22:38:00	"	2SC2238(O,Y)	"		
D101	iF 00:07:90	Varistor	MV12	バ リ ス タ		
D102	iF 00:00:40	Diode	1S1555	ダ イ オ ード		
D103	iF 00:15:10	Zener Diode	HZ-6C1L	ツェナーダイオード		
D104~109	iF 00:00:40	Diode	1S1555	ダ イ オ ード		
D110	iF 00:07:90	Varistor	MV12	バ リ ス タ		
D111	iF 00:00:40	Diode	1S1555	ダ イ オ ード		
D112,113	iF 00:07:90	Varistor	MV12	バ リ ス タ		
D114	iF 00:00:40	Diode	1S1555	ダ イ オ ード		
D115	iF 00:15:10	Zener Diode	HZ-6C1L	ツェナーダイオード		
D116	iF 00:00:40	Diode	1S1555	ダ イ オ ード		
D117	iF 00:15:10	Zener Diode	HZ-6C1L	ツェナーダイオード		
D118,119	iF 00:07:90	Varistor	MV12	バ リ ス タ		
D120	iF 00:00:40	Diode	1S1555	ダ イ オ ード		
D121	iF 00:07:90	Varistor	MV12	バ リ ス タ		
D122	iF 00:00:40	Diode	1S1555	ダ イ オ ード		
D123~128	iF 00:07:90	Varistor	MV12	バ リ ス タ		
D129,130	iF 00:00:40	Diode	1S1555	ダ イ オ ード		
D131~134	iF 00:15:10	Zener Diode	HZ-6C1L	ツェナーダイオード		
D135,136	iF 00:00:40	Diode	1S1555	ダ イ オ ード		
D157~160	iF 00:14:00	"	1SS82	"		
D161,162	iF 00:00:40	"	1S1555	"		
D163~168	iF 00:15:10	Zener Diode	HZ-6C1L	ツェナーダイオード		
D169~172	iF 00:00:40	Diode	1S1555	ダ イ オ ード		
D173	iF 00:07:90	Varistor	MV12	バ リ ス タ		
	BA 07:90:30	Heat Sink		放 熱 板		
	LA 00:03:70	Pipe Lug	φ2 x 6.1	パイプラグ		
	BB 06:88:50	Bus-Bar (F)		ブースバー (F)		

\* New Parts (新規部品)



Ref. No.	Part No.	Description	部 品 名	Remarks	Common Model	Markets		
	BB 06:89:00	Booth-Bar (E)		ブースバー(E)				
	CB 09:28:00	Bush		ワンタッチブッシュ				
	CB 09:30:90	Collar		ワンタッチカラー				
	EH 02:60:80	Pan Head Screw	M2.6x8 ZMC2-Y	セムスナベ小ネジ	(Sems-Type)			
	iL 00:02:70	Mica Base	3P	マイカベース				
	CB 07:28:80	Bush		絶縁ブッシュ				
	LA 00:41:20	Test Point Pin	1P	テストポイントピン				
	CB 09:85:80	Spacer		スペーサー				
※	NA 07:42:80	Bias Power (+) Circuit Board		バイアスパワー(+)シート				
※	C401	FV 24:71:50 Electrolytic Cap.	15μF 25V	ケミコン				
	C402	FT 15:31:00 Polypropylene Film Cap.	0.001μF 100V	ポリプロピレンフィルムコン				
	C403	FU 35:21:50 Mica Cap.	150pF	マイカコン				
	C404	FA 15:44:70 Mylar Cap.	0.047μF 50V	マイラーコン				
	C405,406	FA 15:34:70 "	0.0047μF 50V	"				
	C407	FA 15:44:70 "	0.047μF 50V	"				
	C408	FA 15:41:00 "	0.01μF 50V	"				
※	C601~605	FT 15:44:70 Polypropylene Film Cap.	0.047μF 100V	ポリプロピレンフィルムコン				
※	R401	HU 75:74:70 Metal Film Resistor	47kΩ	金属被膜抵抗				
※	R402	HU 75:65:60 "	5.6kΩ	"				
※	R403	HU 75:72:20 "	22kΩ	"				
	R404	HU 07:65:60 "	5.6kΩ	"				
※	R405,406	HU 75:61:00 "	1kΩ	"				
※	R407	HU 75:53:90 "	390Ω	"				
※	R409,410	HU 75:61:00 "	1kΩ	"				
※	R411	HU 75:51:00 "	100Ω	"				
※	R412,413	HU 75:43:30 "	33Ω	"				
※	R414	HU 75:71:00 "	10kΩ	"				
※	R415	HU 75:61:20 "	1.2kΩ	"				
※	R416	HU 75:71:50 "	15kΩ	"				
※	R417	HU 75:61:20 "	1.2kΩ	"				
※	R418,419	HU 75:61:10 "	1.1kΩ	"				
※	R420	HU 75:61:20 "	1.2kΩ	"				
※	R421,422	HL 31:63:90 Metal Oxide Film Resistor	3.9kΩ 1W	酸化金抵抗				
※	R423	HU 75:65:60 Metal Film Resistor	5.6kΩ	金属被膜抵抗				
※	R424,425	HU 75:61:00 "	1kΩ	"				
※	R426	HU 75:65:60 "	5.6kΩ	"				
	R427~429	HU 07:65:60 "	5.6kΩ	"				
	R601,602	HV 35:34:70 Flame Proof Resistor	4.7Ω RDF25	不燃化カーボン抵抗				
	R603,604	HL 31:34:70 Metal Oxide Film Resistor	4.7Ω 1W	酸化金抵抗				
	R605,606	HV 35:53:90 Flame Proof Resistor	390Ω RDF25	不燃化カーボン抵抗				
※	R607~612	HZ 00:13:40 Cement Resistor	0.22Ω 5W	セメント抵抗				
	R613~616	HL 31:34:70 Metal Oxide Film Resistor	4.7Ω 1W	酸化金抵抗				
	R617,618	HV 35:34:70 Flame Proof Resistor	4.7Ω RDF25	不燃化カーボン抵抗				
※	VR401	HT 57:04:10 Metal Grazed Variable Resistor	B50kΩ	メタルグレース抵抗				
※	VR402	HT 57:03:90 "	B20kΩ	"				
※	FR601	HW 81:46:80 Fuse Resistor	68Ω 120mA	ヒューズ抵抗				
	TR401~TR403	iA 09:70:00 Transistor	2SA970(GR,BL)	トランジスタ				
※	TR404	iZ 00:01:20 Dual Transistor	μPA74V	デュアルトランジスタ				

\* New Parts (新規部品)

Ref. No.	Part No.	Description	部 品 名	Remarks	Common Model	Markets		
TR405	iC 18:15:00	Transistor	2SC1815(O,Y,GR)	トランジスタ				
TR406	iA 06:73:10	"	2SA673A(C,D)	"				
TR407 TR408	iC 12:13:10	"	2SC1213A(C,D)	"				
TR409	iA 06:73:10	"	2SA673A(C,D)	"				
TR410 TR411	iC 22:40:00	"	2SC2240(GR,BL)	"				
* TR412	iC 18:85:00	"	2SC1885(S,T)	"				
TR413	iA 09:70:00	"	2SA970(GR,BL)	"				
TR414 TR415	iC 22:40:00	"	2SC2240(GR,BL)	"				
D401~403	iF 00:00:40	Diode	1S1555	ダイオード				
D404	iF 00:14:00	"	1SS82	"				
D405~408	iF 00:00:40	"	1S1555	"				
D409	iF 00:14:00	"	1SS82	"				
D410	iF 00:00:40	"	1S1555	"				
	LA 00:25:00	Wrapping Terminal	1P	i型ラッピング端子板				
	LA 00:03:70	Pipe Lug	φ2 x 6	パイプラグ				
	BB 06:62:90	Ground Washer		アースワッシャー				
	BB 06:88:90	Booth-Bar (D)		ブースバー (D)				
	CB 09:29:90	Wire Crip		ワイアークリップ				
	LA 00:21:40	Wrapping Terminal	P = 10 2P	i型ラッピング端子板				
* NA 07:42:90		Bias Power (-) Circuit Board		バイアスパワー(-)シート				
* C501	FV 24:71:50	Electrolytic Cap.	15μF 25V	ケミコン				
C502	FT 15:31:00	Polypropylene Film Cap.	0.001μF 100V	ポリプロピレンフィルムコン				
C503	FU 35:21:50	Mica Cap.	150pF	マイカコン				
C504	FA 15:44:70	Mylar Cap.	0.047μF 50V	マイラーコン				
C505,506	FA 15:34:70	"	0.0047μF 50V	"				
C507	FA 15:44:70	"	0.047μF 50V	"				
C508	FA 15:41:00	"	0.01μF 50V	"				
* C651~655	FT 15:44:70	Polypropylene Film Cap.	0.047μF 100V	ポリプロピレンフィルムコン				
R501	HU 75:74:70	Metal Film Resistor	47kΩ	金属被膜抵抗				
* R502	HU 75:65:60	"	5.6kΩ	"				
* R503	HU 75:72:20	"	22kΩ	"				
R504	HU 07:65:60	"	5.6kΩ	"				
* R505,506	HU 75:61:00	"	1kΩ	"				
* R507	HU 75:63:90	"	390Ω	"				
* R509,510	HU 75:61:00	"	1kΩ	"				
* R511	HU 75:51:00	"	100Ω	"				
* R512,513	HU 75:43:30	"	33Ω	"				
* R514	HU 75:71:00	"	10kΩ	"				
* R515	HU 75:61:20	"	1.2kΩ	"				
* R516	HU 75:71:50	"	15kΩ	"				
* R517	HU 75:61:20	"	1.2kΩ	"				
* R518,519	HU 75:61:10	"	1.1kΩ	"				
* R520	HU 75:61:20	"	1.2kΩ	"				
* R521,522	HL 31:63:90	Metal Oxide Film Resistor	3.9kΩ 1W	酸金抵抗				
* R523	HU 75:65:60	Metal Film Resistor	5.6kΩ	金属被膜抵抗				
* R524,525	HU 75:61:00	"	1kΩ	"				
* R526	HU 75:65:60	"	5.6kΩ	"				
R527~529	HU 07:65:60	"	5.6kΩ	"				
R651,652	HV 35:34:70	Flame Proof Resistor	4.7Ω RDF25	不燃化カーボン抵抗				

\* New Parts (新規部品)

Ref. No.	Part No.	Description	部 品 名	Remarks	Common Model	Markets		
R653,654	HL 31:34:70	Metal Oxide Film Resistor	4.7Ω 1W	酸 金 抵 抗				
R655,656	HV 35:53:90	Flame Proof Resistor	390Ω RDF25	不 燃 化 カ ー ボ ン 抵 抗				
* R657~662	HZ 00:13:40	Cement Resistor	0.22Ω 5W	セ メ ン ト 抵 抗				
R663~666	HL 31:34:70	Metal Oxide Film Resistor	4.7Ω 1W	酸 金 抵 抗				
R667,668	HV 35:34:70	Flame Proof Resistor	4.7Ω RDF25	不 燃 化 カ ー ボ ン 抵 抗				
* VR501	HT 57:04:10	Metal Grazed Variable Resistor	B50kΩ	メ タ ル グ レ ー ズ 抵 抗				
* VR502	HT 57:03:90	"	B20kΩ	"				
FR651	HW 81:46:80	Fuse Resistor	68Ω 120mA	ヒ ュ ー ズ 抵 抗				
TR501~ TR503	iA 09:70:00	Transistor	2SA970(GR,BL)	ト ラ ン ジ ス タ				
TR504	iZ 00:01:20	Dual Transistor	μPA74V	デュアルトランジスタ				
TR505	iC 18:15:00	Transistor	2SC1815(O,Y,GR)	ト ラ ン ジ ス タ				
TR506	iA 06:73:10	"	2SA673A (C,D)	"				
TR507 TR508	iC 12:13:10	"	2SC1213A(C,D)	"				
TR509	iA 06:73:10	"	2SA673A(C,D)	"				
TR510 TR511	iC 22:40:00	"	2SC2240(GR,BL)	"				
TR512	iC 18:85:00	"	2SC1885(S,T)	"				
TR513	iA 09:70:00	"	2SA970(GR,BL)	"				
TR514 TR515	iC 22:40:00	"	2SC2240(GR,GL)	"				
D501~503	iF 00:00:40	Diode	1S1555	ダ イ オ ー ド				
D504	iF 00:14:00	"	1SS82	"				
D505~508	iF 00:00:40	"	1S1555	"				
D509	iF 00:14:00	"	1SS82	"				
D510	iF 00:00:40	"	1S1555	"				
	LA 00:25:00	Wrapping Terminal	1P	i 型 ラ ッ ピ ン グ 端 子 板				
	LA 00:03:70	Pipe Lug	φ2 x 6	パ イ プ ラ グ				
	BB 06:62:90	Ground Washer		ア ー ス ワ ッ シ ャ ー				
	BB 06:88:90	Booth-Bar (D)		ブ ー ス バ ー (D)				
	CB 09:29:90	Wire Crip		ワ イ ア ー ク リ ッ プ				
	LA 00:21:40	Wrapping Terminal	P = 10 2P	i 型 ラ ッ ピ ン グ 端 子 板				
* NA 07:43:00		Power Circuit Board		出 力 シ ー ト				
* C701,702	FT 15:44:70	Polypropylene Film Cap.	0.047μF 100V	ポ リ プ ロ ピ レ ン フ ィ ル ム コ ン				
* L701,702	GD 90:03:20	Coil	1μH	空 芯 コ イ ル				
R701~704	HL 32:41:00	Metal Oxide Film Resistor	10Ω 2W	酸 金 抵 抗				
D701,702	iH 00:07:10	Diode	W06C	ダ イ オ ー ド				
RY701 RY702	KC 00:03:10	Relay	AP5421 HL2-P-DC12V	リ レ ー				
	LA 00:03:70	Pipe Lug	φ2 x 6	パ イ プ ラ グ				
	LA 00:05:30	Eyelet		ハ ネ ツ キ ハ ト メ				
	LA 00:23:70	Wrapping Terminal	P = 5 4P	L 型 ラ ッ ピ ン グ 端 子 板				
	BB 06:88:80	Booth-Bar (C)		ブ ー ス バ ー (C)				
* NA 07:43:10		Relay Circuit Board		リ レ ー シ ー ト				
C751	FZ 00:06:80	Metalized Mylar Cap.	0.1μF 250V	M M コ ン				

\* New Parts (新規部品)

Ref. No.	Part No.	Description	部 品 名	Remarks	Common Model	Markets
D751	iH 00:07:10	Diode	W06C	ダイオード		
RY751 RY752	KC 00:03:10	Relay	AP5421 HL2-P-DC12V	リレー		
	LA 00:23:50	Wrapping Terminal	P = 5 2P	L型ラッピング端子板		
	LA 00:05:30	Eyelet		ハネツキハトメ		
	CB 09:28:00	Bush	M3	ワンタッチブッシュ		
	CB 09:28:10	Collar	h = 7.5	ワンタッチカラー		
※	NA 07:43:20	Muting Circuit Board		ミュートイングシート		
	C801~804	FZ 00:06:80 Mylar Cap.	0.1μF 250V	マイラーコン		
	C805,806	FV 27:91:00 Electrolytic Cap.	1000μF 63V	ケミコン		
	C807,808	FA 15:42:20 Mylar Cap.	0.022μF 50V	マイラーコン		
	C809,810	FV 29:71:00 Electrolytic Cap.	10μF 100V	ケミコン		
※	C812,813	FU 30:21:00 Mica Cap.	100pF	マイカコン		
	C814,815	FT 15:41:00 Polypropylene Film Cap.	0.01μF 100V	ポリプロピレンフィルムコン		
	C816,817	FV 26:63:30 Electrolytic Cap.	3.3μF 50V	ケミコン		
	C818,819	FV 24:81:00 "	100μF 25V	"		
	C822,823	FV 26:74:70 "	47μF 50V	"		
	C824~827	FA 15:42:20 Mylar Cap.	0.022μF 50V	マイラーコン		
	C828	UW 85:71:00 Electrolytic Cap.	10μF 35V	ケミコン		
	C829	UW 84:91:00 "	1000μF 25V	"		
	C832	UW 83:71:00 "	10μF 16V	"		
	C833,834	FM 22:71:00 "	10μF 25V	B P コン		
	C835,836	UW 86:64:70 "	4.7μF 50V	"		
	C837	FA 15:41:00 Mylar Cap.	0.01μF 50V	マイラーコン		
	C838	UW 85:71:00 Electrolytic Cap.	10μF 35V	ケミコン		
	C839	UW 83:81:00 "	100μF 16V	"		
	C840	UW 86:61:00 "	1μF 50V	"		
	L801,802	GE 30:02:30 RF Coil	10μH	RFチョークコイル		
	R801,802	HV 35:44:70 Flame Proof Resistor	47Ω RDF25	不燃化カーボン抵抗		
	R803~806	HV 35:34:70 "	4.7Ω "	"		
※	R807,808	HU 75:61:20 Metal Film Resistor	1.2kΩ	金属被膜抵抗		
※	R809,810	HU 75:71:80 "	18kΩ	"		
※	R811,812	HU 75:61:20 "	1.2kΩ	"		
※	R813,814	HU 75:61:50 "	1.5kΩ	"		
※	R815,816	HU 75:73:90 "	39kΩ	"		
※	R817,818	HU 75:51:80 "	180Ω	"		
※	R819,820	HU 75:72:20 "	22kΩ	"		
※	R821,822	HU 75:51:50 "	150Ω	"		
※	R823,824	HU 75:51:00 "	100Ω	"		
※	R825,826	HU 75:55:60 "	560Ω	"		
※	R827~830	HU 75:51:00 "	100Ω	"		
※	R831,832	HU 75:52:20 "	220Ω	"		
※	R833,834	HU 75:41:00 "	10Ω	"		
※	R835~838	HU 75:61:00 "	1kΩ	"		
※	R839,840	HU 75:71:00 "	10kΩ	"		
※	R841,842	HU 75:52:20 "	220Ω	"		
※	R843,844	HU 07:71:30 "	13kΩ	"		
※	R845,846	HU 07:71:00 "	10kΩ	"		
※	R847,848	HU 75:64:70 "	4.7kΩ	"		

※ New Parts (新規部品)

Ref. No.	Part No.	Description	部 品 名	Remarks	Common Model	Markets		
* R849	HU 75 61:00	Metal Film Resistor	1kΩ	金 属 被 膜 抵 抗				
* R850,851	HU 75 72:20	"	22kΩ	"				
* R852,853	HU 75 81:00	"	100kΩ	"				
* R854,855	HU 75 74:70	"	47kΩ	"				
* R856,857	HU 75 65:60	"	5.6kΩ	"				
* R858	HU 75 61:20	"	1.2kΩ	"				
* R859,860	HU 75 71:00	"	10kΩ	"				
* R861,862	HU 75 66:80	"	6.8kΩ	"				
* R863,864	HU 75 61:20	"	1.2kΩ	"				
* R865	HU 75 63:90	"	3.9kΩ	"				
* R866	HU 75 74:70	"	47kΩ	"				
* R867	HU 75 61:20	"	1.2kΩ	"				
R868	HU 07 56:80	"	680Ω	"				
* R869	HU 75 64:70	"	4.7kΩ	"				
* R870	HU 75 61:20	"	1.2kΩ	"				
* R871	HU 75 63:30	"	3.3kΩ	"				
* R872	HU 75 71:00	"	10kΩ	"				
* R873	HU 75 64:70	"	4.7kΩ	"				
* R874	HU 75 62:70	"	2.7kΩ	"				
* R875	HU 75 62:20	"	2.2kΩ	"				
* R876	HU 75 61:00	"	1kΩ	"				
* R877	HU 75 82:20	"	220kΩ	"				
* R878-882	HU 75 61:00	"	1kΩ	"				
* R883	HU 75 62:70	"	2.7kΩ	"				
* VR801 VR802	HT 57 02:90	Metal Grazed Variable Resistor	B1.5kΩ	メタルグレース抵抗				
TR801	iA 09 70:00	Transistor	2SA970(GR,BL)	ト ラ ン ジ ス タ				
TR802 TR803	iC 22 40:00	"	2SC2240(GR,BL)	"				
TR804	iA 09 70:00	"	2SA970(GR,BL)	"				
* TR805	iA 07 33:40	"	2SA733A(Q,P)	"				
TR806	iC 14 00:20	"	2SC1400(E)	"				
TR807	iA 07 77:30	"	2SA777(Q,R)	"				
TR808	iC 15 09:30	"	2SC1509(Q,R)	"				
TR809	iB 05 66:10	"	2SB566A(B,C,D)	"				
TR810	iD 04 76:40	"	2SD476A(B,C)	"				
TR811	iC 15 09:30	"	2SC1509(Q,R)	"				
TR812	iA 07 77:30	"	2SA777(Q,R)	"				
TR813	iA 09 12:10	"	2SA912(Q,R)	"				
TR814	iC 18 85:10	"	2SC1885(Q,R)	"				
TR815	iA 07 98:00	Dual Transistor	2SA978	デュアルトランジスタ				
TR816	iC 15 83:00	"	2SC1583(E,F)	"				
TR817	iC 22 91:00	"	2SC2291(F,G,H)	"				
TR818	iA 09 95:00	"	2SA995(F,G,H)	"				
TR819	iC 15 83:00	"	2SC1583(E,F)	"				
TR820	iA 07 98:00	"	2SA798	"				
TR821	iB 05 66:10	Transistor	2SB566A(B,C,D)	ト ラ ン ジ ス タ				
TR822 TR823	iC 23 20:40	"	2SC2320(F)	"				
TR824	iA 07 33:40	"	2SA733A(Q,P)	"				
TR825	iC 23 20:40	"	2SC2320 (F)	"				
TR826	iA 07 33:40	"	2SA733A(Q,P)	"				
TR827	iA 07 77:30	"	2SA777(Q,R)	"				
TR828	iC 23 20:40	"	2SC2320(F)	"				

\* New Parts (新規部品)

Ref. No.	Part No.	Description	部 品 名	Remarks	Common Model	Markets		
TR829 TR830	iA 07:77:30	Transistor	2SA777(Q,R)	トランジスタ				
TR831 TR832	iC 23:20:40	"	2SC2320(F)	"				
TR833	iE 10:05:30	FET	2SK68A(M)	F E T				
D801	iH 00:08:20	Diode Rectifier	UB-152	整流ダイオード				
D802,803	iF 00:02:20	Zener Diode	WZ-310	ツェナーダイオード				
D804,805	iF 00:00:40	Diode	1S1555	ダイオード				
D806,807	iF 00:14:00	"	1SS82	"				
D808,809	iF 00:07:90	Varistor	MV12	バリスタ				
D810,811	iF 00:00:40	Diode	1S1555	ダイオード				
D812,813	iF 00:15:10	Zener Diode	HZ-6C1L	ツェナーダイオード				
D814~817	iF 00:00:40	Diode	1S1555	ダイオード				
D818,823	iF 00:15:10	Zener Diode	HZ-6C1L	ツェナーダイオード				
D824	iH 00:08:20	Diode Rectifier	UB-152	整流ダイオード				
D825	iF 00:14:00	Diode	1SS82	ダイオード				
D826	iF 00:03:50	Zener Diode	WZ130	ツェナーダイオード				
D827~831	iF 00:00:40	Diode	1S1555	ダイオード				
D832	iF 00:15:10	Zener Diode	HZ-6C1L	ツェナーダイオード				
D833~838	iF 00:00:40	Diode	1S1555	ダイオード				
D839	iF 00:15:10	Zener Diode	HZ-6C1L	ツェナーダイオード				
F801,802	KB 00:02:30	Fuse	2.0AT 125V	ヒューズ				
F803,804	KB 00:02:10	"	1.0AT 125V	"				
	LA 00:23:60	Wrapping Terminal	P = 5 3P	L型ラッピング端子板				
	LA 00:23:80	"	P = 5 5P	"				
	LA 00:24:00	"	P = 7.5 3P	"				
	LA 00:03:70	Pipe Lug	φ2×6	パイプラグ				
	LB 20:09:00	Fuse Holder Pin		ヒューズホルダーピン				
	iL 00:02:70	Mica Base	3P	マイカベース				
	CB 07:28:80	Bush		絶縁ブッシュ				
	BA 07:89:20	Heat Sink		放熱板 A				
	BA 07:89:30	"		放熱板 B				
	LB 00:20:20	Connector	2P	スナップメイトコネクタ				
	LB 00:20:40	"	4P	"				
	EK 31:00:60	Sems Pan Head Screw	M2.6x8(FCM3-B)	セムスナベ小ネジ				
	Ei 33:00:80	Bind Head Tapping Screw	3x8 (ZMC2-B)	バインドタッピンネジ				
	ED 33:00:80	Bind Head Screw	M3x8(ZMC2-B)	バインド小ネジ				
	LA 00:41:20	Test Point Pin		テストポイントピン				
※	NA 07:43:30	Push Switch Circuit Board		ブッシュスイッチシート				
C901~903	FA 41:41:00	Mylar Cap.	0.01μF 50V	マイラーコン				
R901	HJ 15:61:00	Carbon Resistor	1kΩ RD25S	カーボン抵抗				
※	SW901	KA 80:16:40	Push Switch	ブッシュスイッチ				
	LB 00:20:20	Connector	2P	スナップメイトコネクタ				
	CB 09:43:60	Print Spacer		プリントスペーサー				
※	NA 07:43:40	LED Triple Circuit Board		LEDトリプルシート				
D901~903	iF 00:14:30	LED	SLP141B	L E D				

※ New Parts (新規部品)



